

# ROBOT MASTER PLUS

SELF PROPELLED ROBOT FOR STRETCH WRAPPING



## JOG CONTROL PANEL WITH COLOR GRAPHIC DISPLAY

- > 6 program recordable
- > rotation speed setting
- > upward speed carriage setting
- > downward speed carriage setting
- > upward cycle setting
- > downward cycle setting
- > reinforce cycle setting
- > upward film tensioning
- > high position film tensioning
- > downward film tensioning
- > low position film tensioning
- > manual upward/downward carriage
- > upward/downward cycle
- > only upward
- > top sheet cycle
- > F1 program extra pallet
- > F2 program cylindrical products
- > partial cycles counter
- > total cycles counter
- > delay photocell setting
- > altimeter
- > start from ground level
- > control panel lock
- > ergonomic carriage stop

## LAYOUT ROBOT MASTER PLUS mm[in]

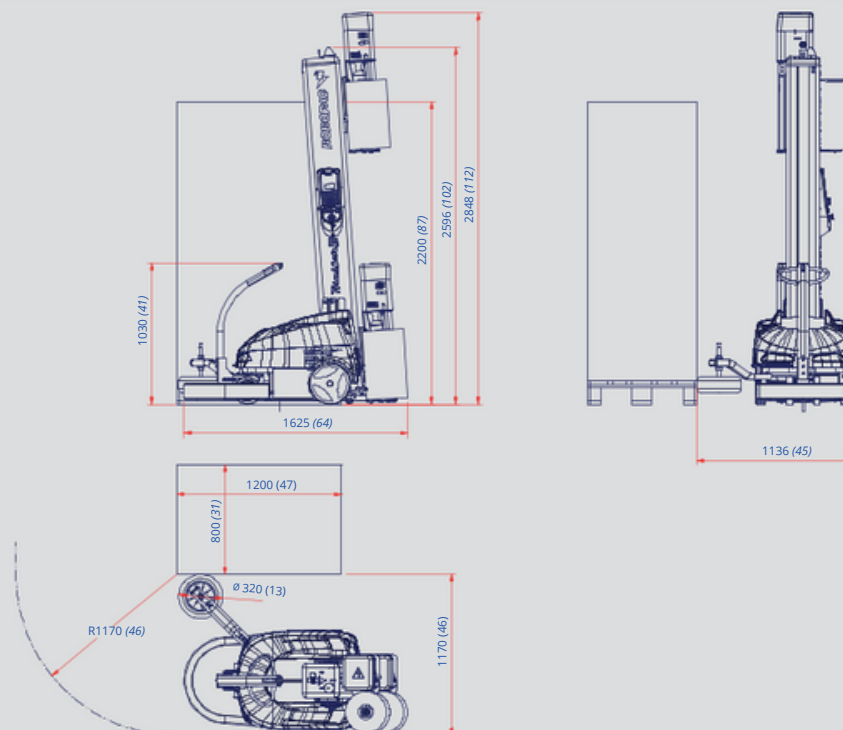

01691 671496

# WHY ROBOT MASTER PLUS?

## CONNECTIVITY

Thanks to the R-connect system (Industry 4.0).

## FLEXIBILITY

Maximum logistics flexibility and warehouse management.

## USABILITY

Thanks to its control panel with jog and intuitive icons.

## SAFETY

Thanks to the safety bumper for immediate stop.

## PERFORMANCE

Suitable for products of any shape, size and weight.  
Excellent compromise between performance and savings.

| CARATTERISTICHE / FEATURES  |          | MASTER PLUS M80 FRD              | MASTER PLUS M80 FR                           | MASTER PLUS M110 FRD             | MASTER PLUS M110 FR                          | MASTER PLUS M110 PDS                         |
|---|----------|----------------------------------|--|----------------------------------|--|--|
| Bancali per carica di batterie<br>Pallet for single battery charger |          | >150                             | >150   | >250                             | >250   | >250   |
| Batterie<br>Batteries   |          | 2 da 12V 75 Ah (C5) AGV          | 2 da 12V 75 Ah (C5) AGV                      | 2 da 12V 110 Ah (C5) lead-acid   | 2 da 12V 110 Ah (C5) lead-acid               | 2 da 12V 110 Ah (C5) lead-acid               |
| Altezza massima prodotto<br>Maximum product height                  | mm(in)   | 2200 (87) std.<br>2400 (94) opt. | 2200 (87) std.<br>2400 (94) opt.             | 2200 (87) std.<br>2400 (94) opt. | 2200 (87) std.<br>2400 (94) opt.             | 2200 (87) std.<br>2400 (94) opt.             |
| Dimensioni minime lavorabili (lxw)<br>Minimum dimensions (lxw)      | mm(in)   | 600x600 (24x24)                  | 600x600 (24x24)                              | 600x600 (24x24)                  | 600x600 (24x24)                              | 600x600 (24x24)                              |
| Peso minimo del prodotto lavorabile<br>Minimum weight               | kg (lbs) | 45 (99)*                         | 45 (99)*                                     | 45 (99)*                         | 45 (99)*                                     | 45 (99)*                                     |
| Tipo carrello / Film carriage type                                  |          | FRD                              | FR   | FRD                              | FR   | PDS  |
| Tiro film<br>Film stretch   |          | manuale<br>manual                | regolabile da pannello/adjustable from panel | manuale<br>manual                | regolabile da pannello/adjustable from panel | regolabile da pannello/adjustable from panel |
| Pre-stiro film / Film pre-stretch                                   |          | n.a.                             | n.a.   | n.a.                             | n.a.   | fisso / fixed 250% std.                      |
| Tensione di alimentazione / Power supply                            | V        | 100-240 1Ph                      | 100-240 1Ph                                  | 100-240 1Ph                      | 100-240 1Ph                                  | 100-240 1Ph                                  |
| Potenza installata / Installed power                                | kW       | 0,3                              | 0,3  | 0,3                              | 0,3  | 0,3  |
| Velocità di rotazione / Rotation speed                              | m/min    | 35+65                            | 35+65  | 35+65                            | 35+65  | 35+65  |
| Velocità salita-discesa carrello<br>Carriage up-down speed          | m/min    | 1,5+4,6                          | 1,5+4,6                                      | 1,5+4,6                          | 1,5+4,6                                      | 1,5+4,6                                      |
| Dimensioni massime bobina (hxø)<br>Maximum reel dimensions (hxø)    | mm(in)   | 500x300 (20x12)                  | 500x300 (20x12)                              | 500x300 (20x12)                  | 500x300 (20x12)                              | 500x300 (20x12)                              |
| Peso massimo bobina / Max. Reel weight                              | kg (lbs) | 20 (44)                          | 20 (44)                                      | 20 (44)                          | 20 (44)                                      | 20 (44)                                      |
| Spessore film / Film thickness                                      | µm       | 7+35                             | 7+35   | 7+35                             | 7+35   | 7+35   |
| Inforcabilità / Forklift  |          | posteriore / rear                | posteriore / rear                            | posteriore / rear                | posteriore / rear                            | posteriore / rear                            |

\* disponibile solo con carrello pds  
only available with pds film carriage

The contents of this catalog have been verified before the press. Robopac reserves the right to modify in every moment the technical characteristics of the products and accessories illustrated in the present document.