

# Ag-Mac v450 Baler

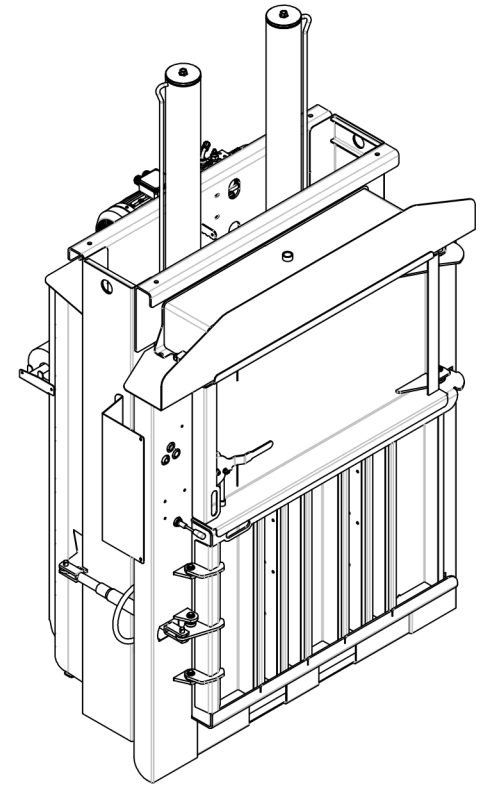
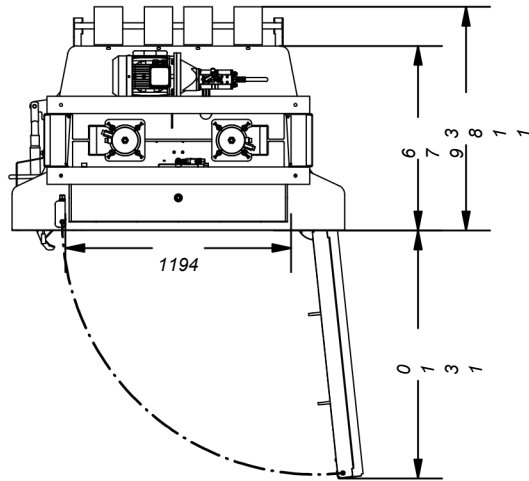
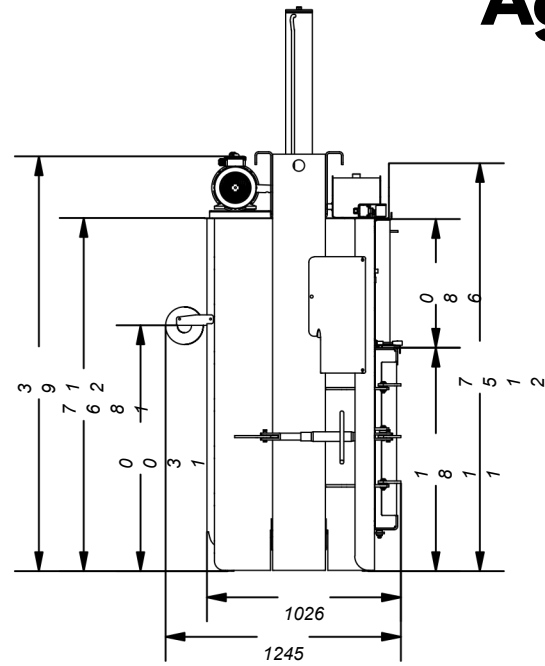
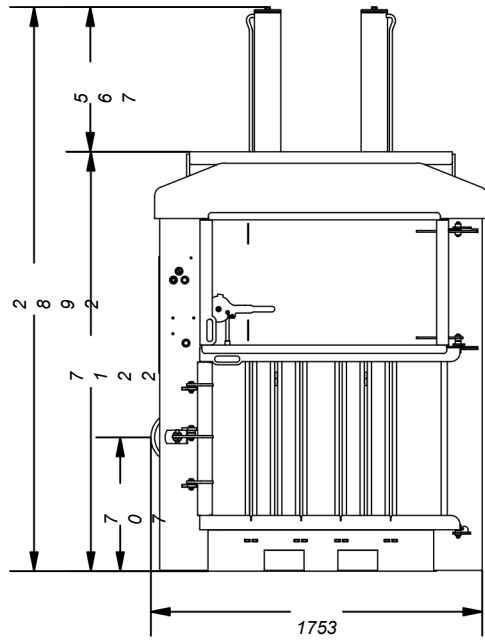

All dimensions in mm					Part/Assembly No:	Sheetmetal Thickness:	Material:	Title:	Mass (Approximate)
Tolerance Table					45 0.000 .0000 .MR 2			Ag-Mac v450 Baler	N/A
ITEM	DIM	<30	<120	<315	<1000	>2000	Pr od uc t( s ) :		Sheet No:1 of 1
Centre Distance		□ 0.2	□ 0.2	□ 0.2	□ 0.3	□ 0.5	ASSEMBLY		
General Dimensions		□ 0.2	□ 0.25	□ 0.25	□ 0.5	□ 0.7	Surface Finish: Clean and free from sharp edges & burrs		
Bend & Assy. Dimensions		□ 0.2	□ 0.3	□ 0.5	□ 0.8	□ 1.2	Additional Details:		DO NOT SCALE

WHERE USED: